

# Flasher Cans

CF13JL-02

## BRITE LED TECH PRODUCT

1 Year Warranty

12 Volt 3 Pin LED Flasher can



LED Flasher can's can be used when replacing all or only some of the existing globes with LED's, due to LED's drawing less power this can trigger the indicators to rapid Flash, which this would then rectify the problem.

If your vehicle has a globe-out warning system for stop/tail or indicators then we suggest using the load resistors as these will reduce the flash rate on indicators back to normal and also correct the globe out warning light from coming on.

Australian standards for indicators are 60 to 120 flashes per minute.

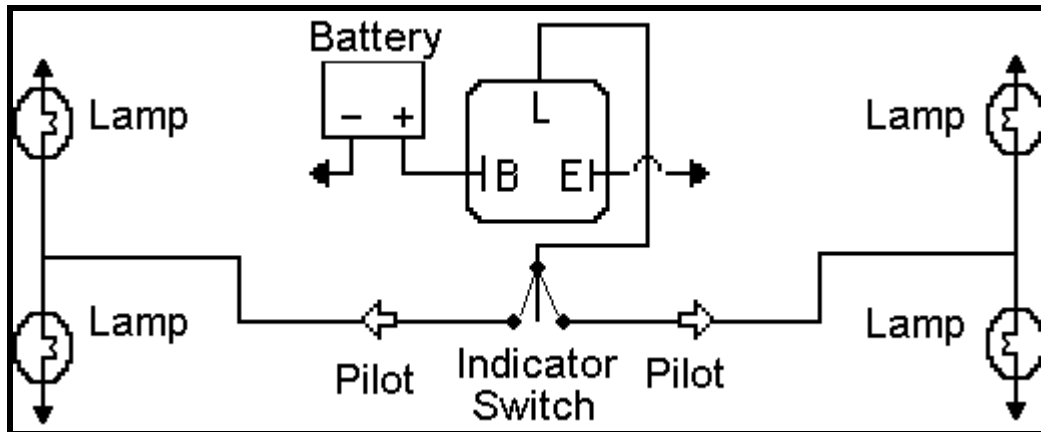

Flasher Cans are marked with the international pin identification system as demonstrated in the chart below.

<b>L</b>	Lamps or Indicator switch	<b>P</b>	Pilot
<b>X</b>	Battery (+) or Ignition	<b>B</b>	Battery (+) or Ignition
<b>E</b>	Earth (-)	<b>49</b>	Battery (+) or Ignition
<b>49a</b>	Lamps or Indicator switch	<b>31</b>	Earth (-)
<b>30B</b>	Hazard Switch (+)	<b>+</b>	Battery (+) or Ignition
<b>-</b>	Earth (-)	<b>C</b>	Vehicle Pilot
<b>C</b>	1st Trailer Pilot	<b>C3</b>	2nd Trailer Pilot